

SECTION 2E

TIRES AND WHEELS

TABLE OF CONTENTS

<p>Specifications 2E-1</p> <p style="padding-left: 20px;">Tire Size and Pressure Specifications 2E-1</p> <p style="padding-left: 20px;">Inflation Pressure Conversion Specifications 2E-2</p> <p style="padding-left: 20px;">Fastener Tightening Specifications 2E-2</p> <p>Diagnosis 2E-2</p> <p style="padding-left: 20px;">Wheel Runout 2E-2</p> <p>Maintenance and Repair 2E-3</p> <p style="padding-left: 20px;">On-Vehicle Service 2E-3</p> <p style="padding-left: 20px;">Wheel 2E-3</p> <p style="padding-left: 20px;">On-Vehicle Balancing 2E-4</p> <p style="padding-left: 20px;">Unit Repair 2E-5</p> <p style="padding-left: 20px;">Alloy Wheel Porosity 2E-5</p> <p style="padding-left: 20px;">Alloy Wheel Refinishing 2E-5</p> <p style="padding-left: 20px;">Off-Vehicle Balancing 2E-7</p>	<p style="padding-left: 20px;">Correcting Non Uniform Tires 2E-7</p> <p style="padding-left: 20px;">Tire and Wheel Match Mounting 2E-8</p> <p style="padding-left: 20px;">Tire Mounting and Dismounting 2E-8</p> <p>General Description and System</p> <p>Operation 2E-9</p> <p style="padding-left: 20px;">Tire and Wheel Balancing 2E-9</p> <p style="padding-left: 20px;">Tire Chain Usage 2E-10</p> <p style="padding-left: 20px;">Tires 2E-10</p> <p style="padding-left: 20px;">All Season Tires 2E-11</p> <p style="padding-left: 20px;">Metric Sized Tires 2E-11</p> <p style="padding-left: 20px;">Label 2E-11</p> <p style="padding-left: 20px;">Spare Tire 2E-11</p> <p style="padding-left: 20px;">Wheels 2E-11</p> <p style="padding-left: 20px;">Inflation of Tires 2E-11</p>
--	---

SPECIFICATIONS

TIRE SIZE AND PRESSURE SPECIFICATIONS

Inflation Pressure at Full Load

Engine	Tires	Wheel	Front		Rear	
			kPa	psi	kPa	psi
-	-	-	200	29	200	29
2.0 SOHC	195/70R14	5.5Jx14 (Steel)	200	29	200	29
2.0 DOHC	205/60R15	6.0Jx15 (Steel)	200	29	200	29
2.0 SOHC	205/60R15	6.0Jx15 (Alloy)	200	29	200	29
2.0 DOHC	205/60R15	6.0Jx15 (Alloy)	200	29	200	29

INFLATION PRESSURE CONVERSION SPECIFICATIONS

kPa	psi	kPa	psi	kPa	psi
140	20	185	27	235	34
145	21	190	28	240	35
155	22	200	29	250	36
160	23	205	30	275	40
165	24	215	31	310	45
170	25	220	32	345	50
180	26	230	33	380	55

FASTENER TIGHTENING SPECIFICATIONS

Application	N•m	LbFt	Lbin
Wheel Nuts (Alloy Wheel)	100	74	-
Wheel Nuts (Steel Wheel)	100	74	-

DIAGNOSIS

WHEEL RUNOUT

Measure wheel runout with an accurate dial indicator. Measurements may be taken with the wheels either on or off the vehicle, using an accurate mounting surface such as a wheel balancer. Measurements may be taken with or without the tire mounted on the wheel.

Measure radial runout and lateral runout on both the inboard and the outboard rim flanges. With the dial indicator firmly seated next to the wheel and tire assembly, slowly rotate the wheel one revolution and record the indicator reading. If any measurement exceeds the following specifications and there is a vibration that wheel balancing will not correct, replace the wheel. Disregard any indicator readings due to welds, paint runs, or scratches.

Steel Wheels

- Radial runout: 0.8 mm (0.03 inch)
- Lateral runout: 1.0 mm (0.04 inch)

Alloy Wheels

- Radial runout: 0.8 mm (0.03 inch)
- Lateral runout: 1.0 mm (0.04 inch)

Measure free radial runout on the center of the tire tread. The tread can be taped to present a smooth surface. Measure free lateral runout on the outboard side of the tire nearest to the tread.

Steel and Alloy Wheels

- Free radial runout: 1.5 mm (0.06 inch)
- Free lateral runout: 1.5 mm (0.06 inch)

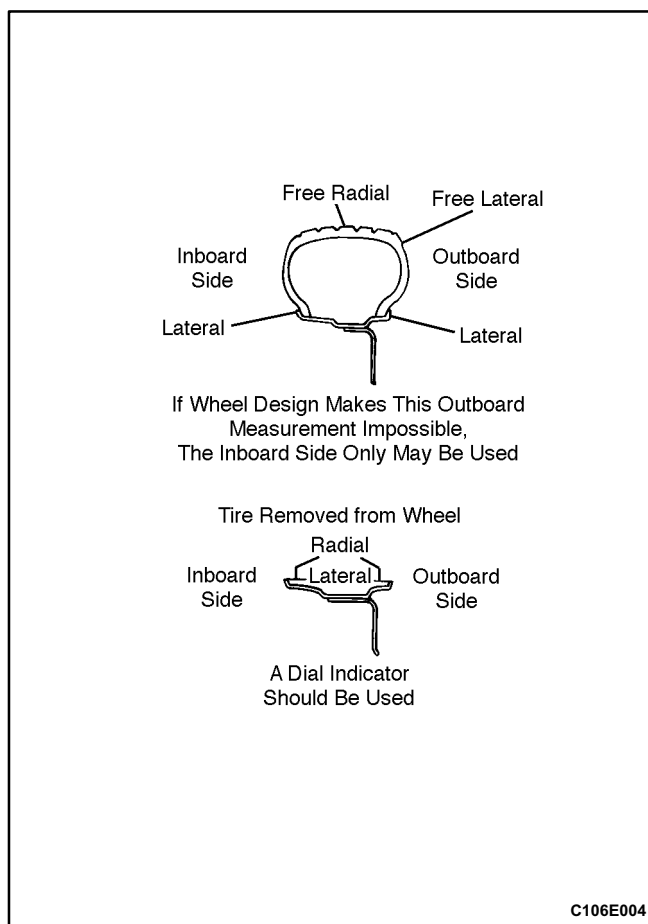

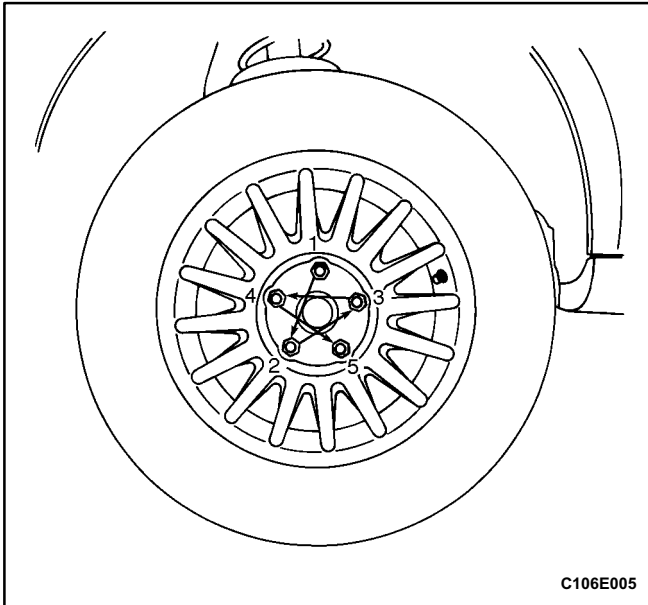

MAINTENANCE AND REPAIR

ON-VEHICLE SERVICE

WHEEL

Removal Procedure

1. Remove the wheel cover.
2. Loosen the wheel nuts.
3. Raise and suitably support the vehicle.
4. Remove the wheel nuts.

Notice: Never use heat to loosen a tight wheel. It can shorten the life of the wheel, the wheel nuts, and the wheel bearings. Excessive force, such as hammering the wheel or tire, can also cause damage and is not recommended. Slight tapping of the wheel sidewall with one's hand or with a rubber mallet is acceptable.

5. Remove the wheel and tire assembly.

Difficulty in removing the wheels from the vehicle can be due to foreign material or to a tight fit between the wheel centerhole and the hub or the rotor. These wheels can be removed by

1. Retightening the wheel nuts on the affected wheel and then loosening the wheel nuts by two turns.
2. Lowering the vehicle and rocking it from side to side as hard as possible, using one or more person's body weight to loosen the wheel.
3. Raising the vehicle and removing the wheel.

Caution: Do not allow the penetrating oil to get on the vertical surfaces between the wheel and the drum (or rotor) because penetrating oil in this area could cause the wheel to work loose as the vehicle is driven, resulting in loss of control and an injury accident.

Penetrating oil is not effective in removing tight wheels. If it is used, however, apply it sparingly and only to the wheel's centerhole area.

Installation Procedure

Notice: Before installing the wheels, remove any buildup of corrosion on the wheel mounting surface and the brake drum or the rotor mounting surface by scraping and brushing them with a wire brush. Installing the wheels without good metal to metal contact at the mounting surfaces can cause the wheel nuts to loosen, which can later allow a wheel to come off while the vehicle is moving. Wheel nuts must be tightened in sequence and to the proper torque to avoid bending the wheel, the brake drum or the rotor.

1. Mount the wheel and tire assembly.
2. Install the wheel nuts in the sequence shown. Do not tighten the wheel nuts.
3. Lower the vehicle.

Tighten

Tighten the wheel nuts to 100 N•m (74 lb•ft).

4. Install the wheel cover.

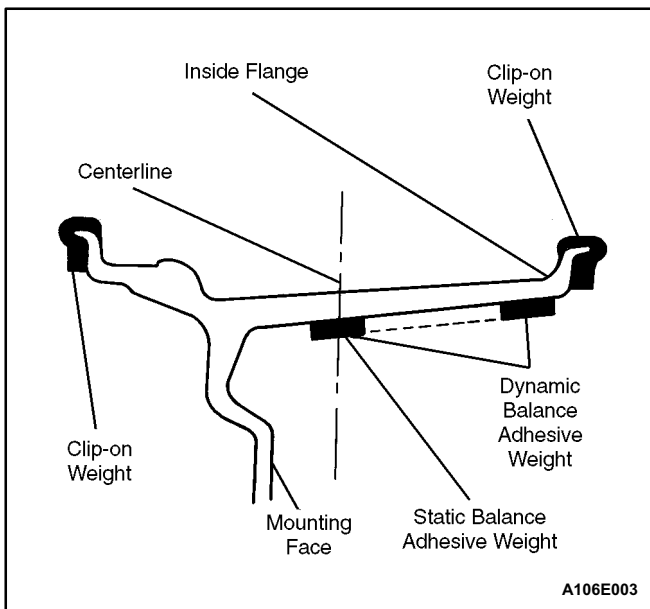

ON-VEHICLE BALANCING

On-vehicle balancing will help correct vibrations due to brake drum, rotor, and wheel cover imbalances.

Notice: Do not allow the front suspension to hang free. When the drive axle is run at an extreme angle, extra vibrations can occur, as well as damage to seals and joints.

1. During on vehicle balancing, do not remove the balance weights from the off vehicle dynamic balance.
2. If more than 1 ounce of additional weight is required, split the weight between the inner and the outer rim flanges.

Caution: Do not spin the drive wheels faster than 55km/h (35 mph) as indicated by the speedometer. This limit is necessary because the speedometer indicates only one half of the actual wheel speed when one drive wheel is spinning and the other drive wheel is stopped. Personal injury and damage may result from high speed spinning.

3. Spin the driven tire and wheel assemblies using the engine.

UNIT REPAIR

ALLOY WHEEL POROSITY

Wheel repairs that use welding, heating or peening are not approved.

1. Raise and suitably support the vehicle.
2. Remove the tire and wheel assembly. Refer to „Wheel” in this section.

Caution: To avoid serious injury, do not stand over the tire when inflating, because the bead may break when it snaps over the safety hump. Do not exceed 275 kPa (40 psi) of air pressure in any tire if the beads are not seated. If 275 kPa (40 psi) of air pressure will not seat the beads, deflate the tire. Relubricate the beads. Reinflate the tire. Overinflation may cause the bead to break and cause serious injury.

3. Locate leaking areas by inflating the tire to 345 kPa (50 psi) and dipping the tire and wheel assembly into a water bath.
4. Mark the leak areas and remove the tire from the wheel.
5. Scuff the inside wheel surface at the leak area with 80grit sandpaper. Clean the leak area with a generalpurpose cleaner.
6. Apply a 3.3 mm (0.13 inch) thick layer of adhesive/sealant to the leak area. Allow it to dry for 12 hours.
7. Install the tire on the wheel. Inflate the tire to 345 kPa (50 psi) and check for leaks as in step 3.
8. Adjust the tire pressure to meet specifications. Refer to „Tire Size and Pressure Specifications” in this section.
9. Balance the tire and wheel assembly. Refer to „Tire and Wheel Balancing” in this section.
10. Install the tire and wheel assembly. Refer to „Wheel” in this section.
11. Lower the vehicle.

ALLOY WHEEL REFINISHING

A protective clear or color coating is applied to the surface of the original equipment cast alloy wheels. Surface degradation can develop if this clear coating is damaged or removed. This can happen at some automatic car wash facilities that use silicone carbide tipped tire brushes to clean white walls and tires. Once the protective coating is damaged, exposure to caustic cleaners or road salt causes further surface degradation. The following procedure details how to strip, clean and recoat alloy wheels.

Caution: To avoid serious personal injury, follow the manufacturer's recommendations and cautions when using these materials.

Required materials

Amchem Alumi Prep No. 33 Stock No. DX533 or equivalent cleaning and conditioning chemical for alloys.

Amchem Alodine No. 1001 Stock No. DX50T or equivalent coating chemical for alloys.

Ditzler Delclear Acrylic Urethane Clear Stock No. DAU 75 or equivalent.

Ditzler Delthane UltraUrethane Additive Stock No. DXR 80 or equivalent.

Before repairing the alloy damage or the clear coat damage, prepare the wheels and tires.

1. Remove the wheel from the vehicle. Refer to „Wheel” in this section.
2. Mark the location of the outboard weights and remove them.
3. Wash the wheel inside and out with a water based all purpose cleaner. Remove the grease and oil with a solvent cleaner.
4. Mask the tire prior to painting.
5. Using a 400 grit wet or dry sandpaper, sand over the painted areas that will not require recoloring. Sanding will promote the adhesion of the clear coat.

Alloy Damage on Wheel Surface

1. Mount the wheel on a brake lathe and spin the assembly slowly.
2. Sand the wheel with a backing block or pad. Hold the backing block or pad flat to the surface of the wheel and sand slowly back and forth from the center to the outer edge of the tire to remove the damage. Use the following sandpaper grits in the order listed:
 - 80 grit.
 - 150 grit.
 - 240 grit.

Clear Coat Damage on Unpainted Wheels

1. Apply the chemical stripper Amchem Alumi Prep No. 33. Use a small 1/4 inch detail brush to apply the stripper around the perimeter and spoke like areas.
2. Remove the stripper according to manufacturer's recommendations.

Caution: To avoid serious personal injury, do not use engine power to rotate the wheel while sanding.

3. Sand the wheel with 240 grit sandpaper by rotating the wheel on a slow spinning brake lathe or by mounting the wheel on the car and spinning it by hand. Sanding restores the machined appearance and promotes adhesion.

After repairing the alloy or clear coat damage, the wheels must be recoated.

Recoating Procedure

Caution: To avoid serious personal injury when applying any two part component paint system, follow the specific precautions provided by the paint manufacturer. Failure to follow these precautions may cause lung irritation and allergic respiratory reaction.

1. Clean the surface.
2. Soak the wheel with Amchem Alumi Prep No. 33 or equivalent for 1 to 3 minutes. Rinse the wheel with water and blow dry.
3. Soak the wheel with Amchem Alodine No. 1001 or equivalent for 1 to 3 minutes. Rinse the wheel with water and blow dry.
4. Finish with Ditzler Delclear Urethane and Ditzler Ultra Urethane Additive or equivalent using three coats.
5. 1st coat spray on a light mist coat, let dry.
6. 2nd coat spray or paint on a light coat, let dry.
7. 3rd coat spray or paint on a heavy double wet coat, let dry.
8. Let the urethane dry for 24 hours or flash for 30 minutes and force dry at 60°C (140°F) for 30 minutes. Allow the urethane to cool for 5 minutes before mounting the wheel on the vehicle.

OFF VEHICLE BALANCING

Perform wheel balancing with an electronic off vehicle balancer. The balancer is easy to use and gives both a static and a dynamic balance. Unlike on vehicle balancing, the off vehicle balancer does not correct for drum or rotor imbalance. This drawback is overcome by its accuracy (usually to within 1/8 ounce). Secure the wheel on the balancer with a cone through the back side of the centerhole, not through the wheel bolt holes.

CORRECTING NON UNIFORM TIRES

There are two ways to correct properly balanced tires which still vibrate. One method uses an automatic machine which loads the tire and buffs small amounts of rubber from high spots on the outer two tread rows. Correction by this method is usually permanent and, if it is done properly, does not significantly affect the appearance or the tread life of the tire. Tire truing with a blade type machine is not recommended because it substantially reduces the tread life and often does not correct the problem permanently.

Another method is to dismount the tire and rotate it 180 degrees on the rim. Do this only on the tire and wheel assemblies which are known to be causing a vibration because this method is just as likely to cause good assemblies to vibrate.

TIRE AND WHEEL MATCH MOUNTING

The tires and wheels are match mounted at the assembly plant. Match mounting aligns the radially stiffest part of the tire, or high spot, to the smallest radius, or low spot, of the wheel.

The high spot of the tire is originally marked by a red paint mark or an adhesive label on the outboard sidewall.

The low spot of the wheel will be at the location of the valve stem.

Before dismounting a tire from its wheel, scribe a line on the tire at the valve stem to assure that it is remounted in the same position.

Replacement tires that are of original equipment quality will have their high and low spot marked in the same manner.

TIRE MOUNTING AND DISMOUNTING

Notice: Use a tire changing machine to mount or dismount the tires. Follow the equipment manufacturer's instructions. Do not use hand tools or tire irons to change tires. These tools may damage the beads or the wheel rim.

1. Clean the rim bead seats with a wire brush or coarse steel wool to remove lubricants, old rubber, and light rust. Before mounting or dismounting a tire, lubricate the bead area well with an approved tire lubricant.

Caution: *To avoid serious injury, do not stand over the tire when inflating it, because the bead may break when it snaps over the safety hump. Do not exceed 275 kPa (40 psi) of air pressure in any tire if the beads are not seated. If 275 kPa (40 psi) of air pressure will not seat the beads, deflate the tire. Relubricate the bead and reinflate the tire. Overinflation may cause the bead to break and cause serious injury.*

2. After mounting the tire, inflate it until the beads are seated. Never exceed 275 kPa (40 psi) to seat the beads.
3. Install the valve core and inflate the tire to the proper pressure. Make sure the locating ring outside of the bead of the tire shows around the rim flanges of the wheel on both sides. This positioning of the tire will insure that the bead of the tire is seated.

GENERAL DESCRIPTION AND SYSTEM OPERATION

TIRE AND WHEEL BALANCING

There are two types of tire and wheel balancing: static and dynamic.

Static balance is the equal distribution of weight around the wheel. Assemblies that are statically unbalanced cause a bouncing action called wheel tramp. This condition may eventually cause uneven tire wear.

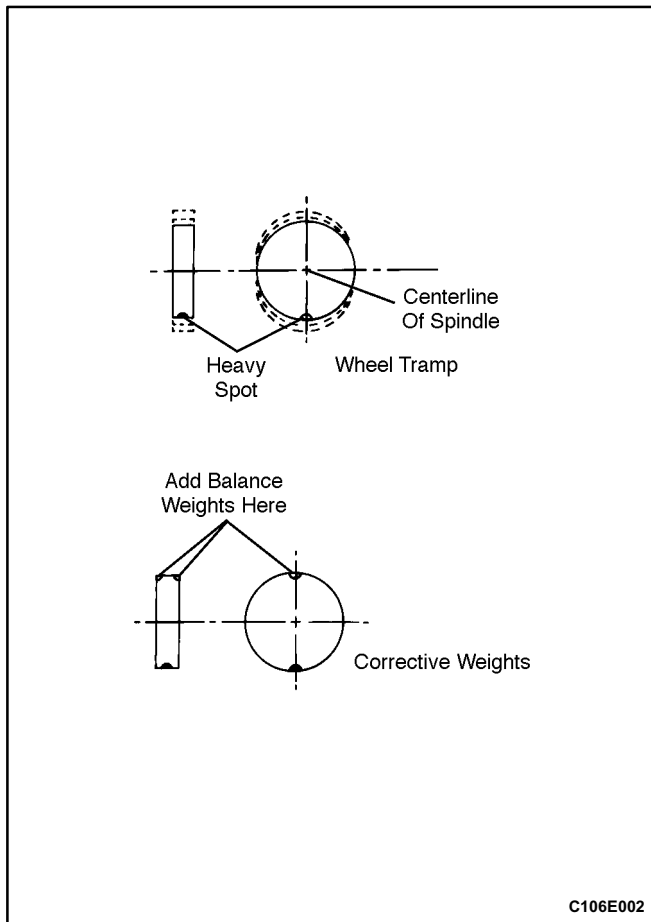

Dynamic balance is the equal distribution of weight on each side of the centerline so that when the assembly spins there is no tendency for it to move from side to side. Assemblies that are dynamically unbalanced may cause wheel shimmy.

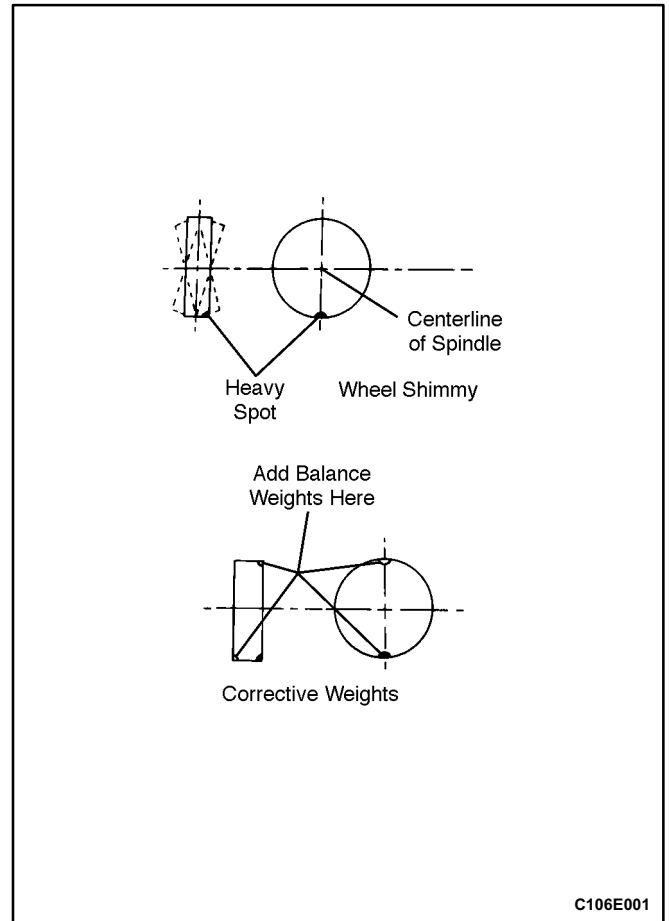

General Balance Precautions

Remove all deposits of foreign material from the inside of the wheel.

Caution: Remove stones from the tread in order to avoid operator injury during spin balancing.

Inspect the tire for any damage. Balance the tire according to the equipment manufacturer's recommendations.

Wheel Weights

If more than 85 grams (3.0 ounces) are needed to static balance the wheel, split the wheel weights as equally as possible between the inboard and the outboard flanges. Balancing the assemblies with factory alloy wheels requires the use of special nylon coated, clip on wheel weights. These weights are designed to fit over the thicker rim flange of the alloy wheel. Install these weights with a plastic tipped hammer.

Adhesive wheel weights are also available. Use the following procedure to install adhesive wheel weights.

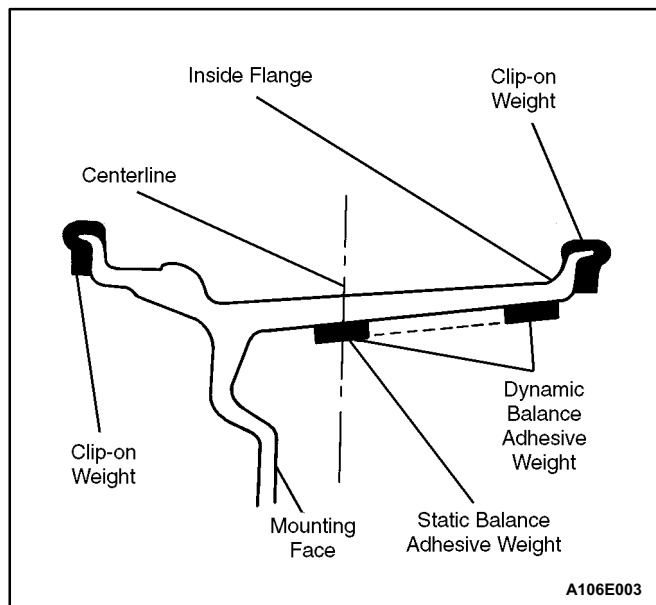

Adhesive Wheel Weight Installation

1. Clean the wheel by sanding it to bare alloy where the wheel weight will be installed.
2. Use a clean cloth or paper towel saturated with a mixture of half isopropyl alcohol and half water to wipe the place where the wheel weight will be installed.
3. Dry the area with hot air. The surface of the wheel should be warm to the touch.
4. Warm the adhesive backing on the wheel weights to room temperature.
5. Remove the tape from the back of the weights. Do not touch the adhesive surface.
6. Apply the the wheel weight and press it on with hand pressure.
7. Secure the wheel weight with a 70-110 N force applied with a roller.

TIRE CHAIN USAGE

Due to limited tire to body clearance on certain vehicles, recommendations for tire chain use are published in the Owner's Manual. When tire chains need to be used, most current Daewoo vehicles require SAE Class „S” tire chains. These may also be designated as 1100 Series, type PL tire chains. These chains are specifically designed to limit the „fly off” effect which occurs when the wheel rotates.

Be sure that only fine link chains are used which do not add more than 15 mm (0.590 inch), including the lock, to the tread surface and the inner sides of the tires.

Manufacturers of tire chains have a specific chain size for each tire size to ensure a proper fit when the chain is installed. Be sure to purchase the correct chains for the tires on which they are to be used. Use rubber adjusters to take up any slack or clearance in loose chains.

Use of chains may adversely affect vehicle handling.

When tire chains are installed, follow these precautions:

- Adjust speed to road conditions.
- Avoid sharp turns.
- Avoid locked wheel braking.

To prevent chain damage to the vehicle, install the chains on the front tires as tightly as possible. Tighten them again after driving 0.4 to 0.8 kilometer (0.3 to 0.5 mile). The use of chains on the rear tires is not recommended because they may contact the vehicle and possibly damage it. If chains must be used on the rear tires, be sure there is sufficient clearance between the chains and the body. Do not exceed 70 km/h (45 mph) or the chain manufacturer's speed limit, if lower. Avoid large bumps, potholes, severe turns and any other maneuvers which could cause the tires to bounce. Follow any other instructions of the chain manufacturer which do not disagree with the above instructions.

REPLACEMENT TIRES

A Tire Performance Criteria (TPC) specification number is molded in the sidewall near the tire size of all original equipment tires. This specification number assures that the tire meets performance standards for traction, endurance, dimensions, noise, handling and rolling resistance. Usually a specific TPC number is assigned to each tire size.

Caution: Do not mix different types of tires on the same vehicle such as radial, bias and bias belted tires except in emergencies, because vehicle handling may be seriously affected and may result in loss of control.

Use only replacement tires with the same size, load range, and construction as the original. The use of any other tire size or construction type may seriously affect ride, handling, speedometer/odometer calibration, vehicle ground clearance, and tire clearance to the body and the chassis. This does not apply to the spare tire furnished with the vehicle.

It is recommended that new tires be installed in pairs on the same axle.

If it is necessary to replace only one tire, pair it with the tire having the most tread to equalize the braking action.

Although they may appear different in tread design, tires built by different manufacturers with identical TPC specifications may be used on the same vehicle.

ALL SEASON TIRES

Most vehicles are now equipped with steel belted all season radial tires as standard equipment. These tires qualify as snow tires, with a 37 percent higher average rating for snow traction than the non all season radial tires previously used. Other performance areas, such as wet traction, rolling resistance, tread life, and air retention, have also been improved. This was done by improvements in both tread design and tread compounds. These tires are identified by an „M + S” molded in the tire sidewall following the size number. The suffix „MS” is also molded in the sidewall after the TPC specification number.

The optional handling tires used on some vehicles are not all season tires. These will not have the „MS” marking after the tire size or the TPC specification number.

PASSENGER METRIC SIZED TIRES

All Daewoo vehicles now use Passenger (P) metric sized tires. Pmetric tires are available in two load ranges: standard load (35 psi maximum) and extra load (41 psi maximum). Most passenger vehicle tires are standard load.

Most P metric tire sizes do not have exact corresponding alphanumeric tire sizes. For example, a P175/70R13 is not exactly equal in size and load-carrying capacity to an FR70 13. For this reason, replacement tires should be of the same TPC specification number as the originals. If Pmetric tires must be replaced with other sizes, consult a tire dealer. Tire companies can best recommend the closest match of alphanumeric to P metric sizes within their own tire lines.

The metric term for measuring tire inflation pressure is the kilopascal (kPa). Tire pressure may be printed in both kPa and psi. One psi equals 6.895 kPa.

See the tire label or refer to „Tire Size and Pressure Specifications” in this section for tire inflation pressures.

TIRE LABEL

The tire label is permanently located on the rear face of the driver's door and should be referred to for tire information. It lists the maximum vehicle load, the tire size (including the spare tire), and the cold inflation pressure (including the spare tire).

SPARE TIRE

This vehicle comes equipped with a full sized spare tire and wheel.

WHEELS

Wheels must be replaced if they are bent, dented, have excessive lateral or radial runout, leak air through welds, have elongated bolt holes, or if the wheel nuts won't stay

tight or are heavily rusted. Wheels with excessive runout may cause vehicle vibration. Replacement wheels must be equivalent to the original equipment wheels in load capacity, diameter, rim width, offset, and mounting configuration. A wheel of improper size or type may affect wheel and bearing life, brake cooling, speedometer/odometer calibration, vehicle ground clearance, and tire clearance to the body and the chassis. The wheel offset is 49 ± 1 mm (1.93 ± 0.04 inches). Steel wheels may be identified by a two or three letter code stamped into the rim near the valve stem. Alloy wheels should have the code, the part number, and the manufacturer ID cast into the back side.

INFLATION OF TIRES

The pressure recommended for any vehicle line is carefully calculated to give a satisfactory ride, handling, tread life, and load carrying capacity.

Tire pressure should be checked monthly or before any extended trip. Check the tires when they are cold, after the vehicle has sat for 3 hours or more or has been driven less than 1 mile. Set the tire pressure to the specifications on the tire label located on the rear face of the driver's door. Tire inflation pressure is also given under „Tire Size and Pressure Specifications” in this section.

Valve caps or extensions should be on the valves to keep dust and water out.

For sustained driving at speeds up to 140 km/h (85 mph), inflate the tires to the pressure recommended on the tire. Sustained driving at speeds faster than 140 km/h (85 mph), even if permitted by law, is not advised unless the vehicle has special high speed tires available from many tire dealers. Tire pressures may increase as much as 41 kPa (6 psi) when the tires are hot.

Higher than recommended tire pressure can cause

- Hard ride
- Tire bruising or damage
- Rapid tread wear at the center of the tire

Lower than recommended pressure can cause

- Tire squeal on turns
- Hard steering
- Rapid and uneven wear on the edges of the tread
- Tire rim bruises and rupture
- Tire cord breakage
- High tire temperatures

Unequal tire pressures on same axle can cause

- Uneven braking
- Steering lead
- Reduced handling
- Swerve on acceleration
- Torque steer